

TRANSIT

—By Alegre Design—





■ **DESCRIPTION**

- ① **PU seat and backrest** 20 mm thickness in back and 25 mm thickness in seat; Moulded over Steel plate 3 mm thickness
Available in different finishes
- ② Seat and backrest joined by an extruded aluminium **central beam**. Silver and white finishes
- ③ Moulded aluminium **trims** available in silver or white finish
- ④ Optional moulded aluminium **Arms** available in silver, white or polished aluminium
- ⑤ **Lower Beam** in extruded aluminium
- ⑥ **Moulded aluminium feet**, silver epoxy finish, 90 micron. Available in silver, white or polished finish. Ready to be fixed to the floor
Black polypropylene (P.P) caps to avoid sliding when sitting in the bench
- ⑦ **Optional** 13 mm compact laminate table. Available in black or white 500 x 300 mm

■ **SIZES**

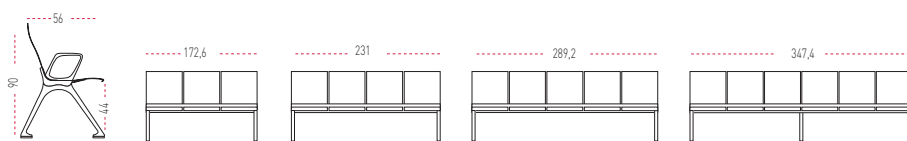

individual seats - high backrest

■ **SIZES**

Total height: from 1726 to 3474 mm
 Total width: 800 or 900 mm
 Seat height: from 440 mm

■ **BACK AND SEAT (finishes)**



Blue Black Grey
 (see finishes and fabric card)



MATERIALS

Maximum use of materials to eliminate and minimize scraps. Use of recyclable and recycled materials in those components that do not affect the functionality and durability.

31,37%
RECYCLED
MATERIALS



PRODUCTION

Maximum optimization of energy use. Minimal environmental impact. Last generation technological systems. Zero discharge of wastewater. No VOC coatings. Processes free of heavy metals, phosphates, OC and COD.

100%
RECYCLABLE
ALUMINIUM, STEEL
& WOOD



TRANSPORT

Detachable systems. Volumes that facilitate the optimization of space. Maximum reduction of energy consumption by transport.

100%
RECYCLABLE
PACKAGE AND THINNER
FREE



USE

Quality and warranty. Long lasting. Replacements available.

EASY
TO CLEAN
AND MAINTAIN



DISPOSAL

Waste reduction. Supplier-manufacturer packaging reuse system. Components are easy to be separated. Inks in packaging are water-based, without solvents.

99,83%
RECYCLABLE
MATERIALS

■ **CERTIFICATES AND REFERENCES**

The different programmes get points in different environmental categories to get the LEED certificate (sustainability, material and resources, water, energy and atmosphere, inner environment quality, innovation and design).



■ **STANDARDS**

TRANSIT has passed tests done in our technical department as well as the tests done in AIDIMME the Technological Institute for furniture. The tests correspond to:

- UNE-EN 16139:2013vc2015. Furniture. Resistance, long lasting, security. Requirements for non domestic use seating.
- UNE-EN 1728:2001. Mobiliario doméstico. Asientos. Métodos de ensayo para la determinación de la resistencia y de la durabilidad.



■ **DESCRIPTION**

- ① 3 mm steel **seats and backs** available in different finishes
- ② Seat and backrest joined by an extruded aluminium **central beam**. Silver and white finishes
- ③ Moulded aluminium **trims** available in silver or white finish
- ④ Optional moulded aluminium **Arms** available in silver, white or polished aluminium
- ⑤ **Lower Beam** in extruded aluminium
- ⑥ **Moulded aluminium feet**, silver epoxy finish, 90 micron. Available in silver, white or polished finish. Ready to be fixed to the floor
Black polypropylene (P.P) caps to avoid sliding when sitting in the bench
- ⑦ **Optional** 13 mm compact laminate table. Available in black or white 500 x 300 mm

■ **SIZES**



individual seats - high backrest

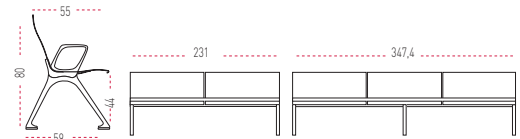

Two large seats - low backrest

■ **SIZES**

Total height: from 1726 to 3474 mm
 Total width: 800 or 900 mm
 Seat height: from 440 mm

■ **BACK AND SEAT (finishes)**



(see finishes and fabric card)



MATERIALS

Maximum use of materials to eliminate and minimize scraps. Use of recyclable and recycled materials in those components that do not affect the functionality and durability.

31,37%
RECYCLED
MATERIALS



PRODUCTION

Maximum optimization of energy use. Minimal environmental impact. Last generation technological systems. Zero discharge of wastewater. No VOC coatings. Processes free of heavy metals, phosphates, OC and COD.

100%
RECYCLABLE
ALUMINIUM, STEEL
& WOOD



TRANSPORT

Detachable systems. Volumes that facilitate the optimization of space. Maximum reduction of energy consumption by transport.

100%
RECYCLABLE
PACKAGE AND THINNER
FREE



USE

Quality and warranty. Long lasting. Replacements available.

EASY
TO CLEAN
AND MAINTAIN



DISPOSAL

Waste reduction. Supplier-manufacturer packaging reuse system. Components are easy to be separated. Inks in packaging are water-based, without solvents.

99,83%
RECYCLABLE
MATERIALS

■ **CERTIFICATES AND REFERENCES**

The different programmes get points in different environmental categories to get the LEED certificate (sustainability, material and resources, water, energy and atmosphere, inner environment quality, innovation and design).



■ **STANDARDS**

TRANSIT has passed tests done in our technical department as well as the tests done in **AIDIMME** the Technological Institute for furniture. The tests correspond to:

- **UNE-EN 16139:2013vc2015.** Furniture. Resistance, long lasting, security. Requirements for non domestic use seating.
- **UNE-EN 1728:2001.** Mobiliario doméstico. Asientos. Métodos de ensayo para la determinación de la resistencia y de la durabilidad.



■ **DESCRIPTION**

- ① 13,53 mm Plywood **seats and backs** available in different finishes: natural beech, natural oak or wengue
- ② Seat and backrest joined by an extruded aluminium **central beam**. Silver and white finishes
- ③ Moulded aluminium **trims** available in silver or white finish
- ④ Optional moulded aluminium **Arms** available in silver, white or polished aluminium
- ⑤ **Lower Beam** in extruded aluminium
- ⑥ **Moulded aluminium feet**, silver epoxy finish, 90 micron. Available in silver, white or polished finish. Ready to be fixed to the floor
Black polypropylene (P.P) caps to avoid sliding when sitting in the bench
- ⑦ **Optional** 13 mm compact laminate table. Available in black or white 500 x 300 mm

■ **SIZES**

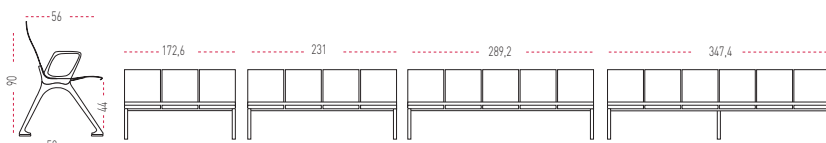

individual seats - high backrest

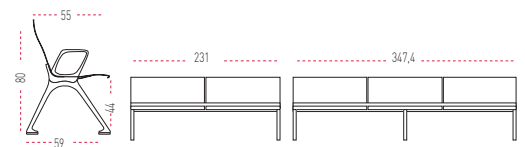

Two large seats - low backrest

■ **SIZES**

Total height: from 1726 to 3474 mm
 Total width: 800 or 900 mm
 Seat height: from 440 mm

■ **BACK AND SEAT (finishes)**

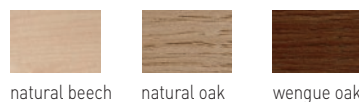

natural beech natural oak wengue oak

(see finishes and fabric card)



MATERIALS

Maximum use of materials to eliminate and minimize scraps. Use of recyclable and recycled materials in those components that do not affect the functionality and durability.

31,37%
RECYCLED
MATERIALS



PRODUCTION

Maximum optimization of energy use. Minimal environmental impact. Last generation technological systems. Zero discharge of wastewater. No VOC coatings. Processes free of heavy metals, phosphates, OC and COD.

100%
RECYCLABLE
ALUMINIUM, STEEL
& WOOD



TRANSPORT

Detachable systems. Volumes that facilitate the optimization of space. Maximum reduction of energy consumption by transport.

100%
RECYCLABLE
PACKAGE AND THINNER
FREE



USE

Quality and warranty. Long lasting. Replacements available.

EASY
TO CLEAN
AND MAINTAIN



DISPOSAL

Waste reduction. Supplier-manufacturer packaging reuse system. Components are easy to be separated. Inks in packaging are water-based, without solvents.

99,83%
RECYCLABLE
MATERIALS

■ **CERTIFICATES AND REFERENCES**

The different programmes get points in different environmental categories to get the LEED certificate (sustainability, material and resources, water, energy and atmosphere, inner environment quality, innovation and design).



■ **STANDARDS**

TRANSIT has passed tests done in our technical department as well as the tests done in AIDIMME the Technological Institute for furniture. The tests correspond to:

- UNE-EN 16139:2013vc2015. Furniture. Resistance, long lasting, security. Requirements for non domestic use seating.
- UNE-EN 1728:2001. Mobiliario doméstico. Asientos. Métodos de ensayo para la determinación de la resistencia y de la durabilidad.

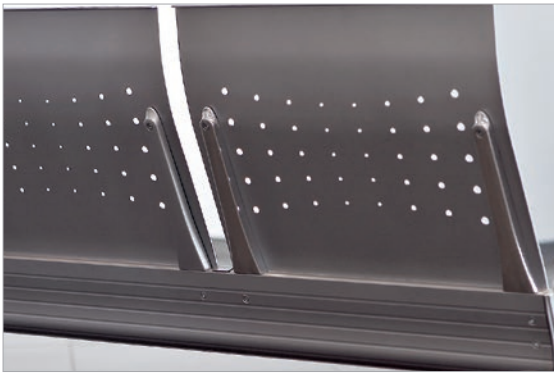

Moulded aluminium back reinforced, 40 x15 mm
(only in metal beam seatings)



Moulded steel seat reinforced, 40 x15 mm
(only in metal beam seatings)



Solid arms, moulded aluminium

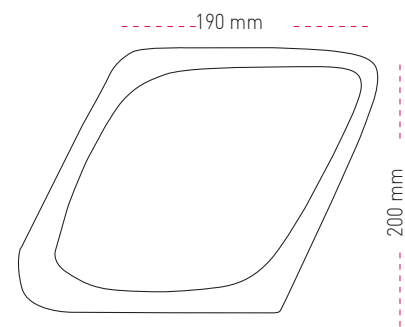

Extruded aluminium central beam 135 height and 202 mm depth 5 mm thickness

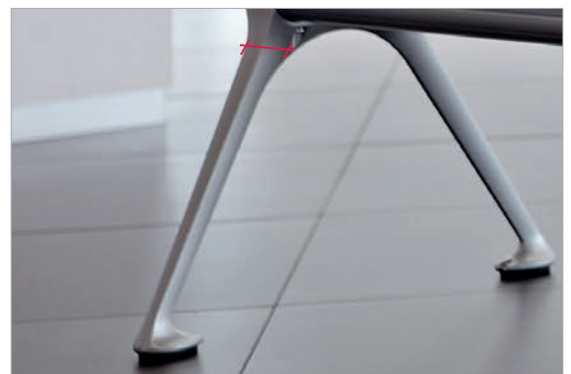

Leg thickness 28 x 34 mm. Solid moulded aluminium



13 mm compact laminate table (optional)

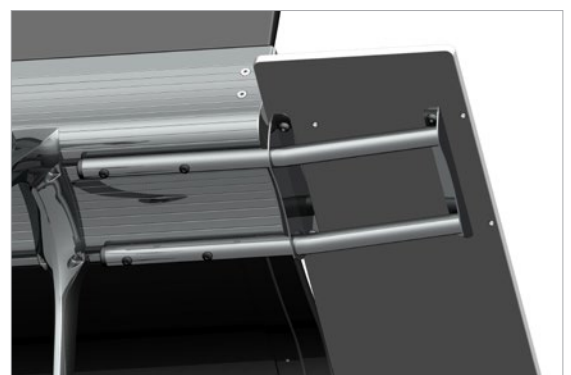

Steel bracket (steel tube \varnothing 25 x 1,5 mm)